

Claro[®]

Custom Acoustical Finishes

including

Metallo[™]



Claro[®]

Claro and Metallo are acoustically transparent coating on acoustic panels and provides superb sound absorbing properties. Claro has the classic appearance of drywall or plaster and can be custom color matched to a paint chip.

Light Reflectance

90% - standard white CSW-100

Fire Testing

In accordance with National Building Code requirements, and ASTM E84 test protocol, Decoustics has complete panel assemblies tested to the ASTM E84 standard, at independent laboratories. Test data for the panel components are also available.

ASTM E84 Test Results

Flamespread 19, Smoke Developed 19.



This impressive boardroom ceiling uses Ceilencio, which features easy installation and Claro finished panels which release downward.



Panel/Edge Reveal Detail

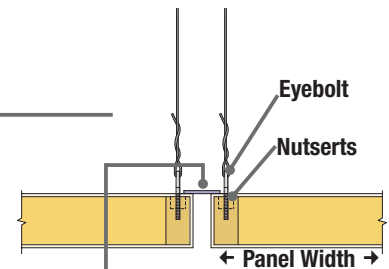

Continuous 1-1/2" wide closure strip

The irregular curvature of the 2-1/4 inch thick panels provides a unique architectural element and exceptional acoustic performance for the renovated offices of this financial management company.

Metallo provides a contemporary look by integrating metalized components to provide luster and sparkle.

Custom-curved panels in a Metallo finish provide a dramatic and innovative solution to the challenging acoustical environment of this casino lounge. The specially-designed, lightweight ceiling panels are suspended 3 stories above the floor with the use of only a single rod.



College of Art auditorium using a combination of reflective and 2" absorptive panels finished in Metallo.

Custom Colors for Claro and Metallo

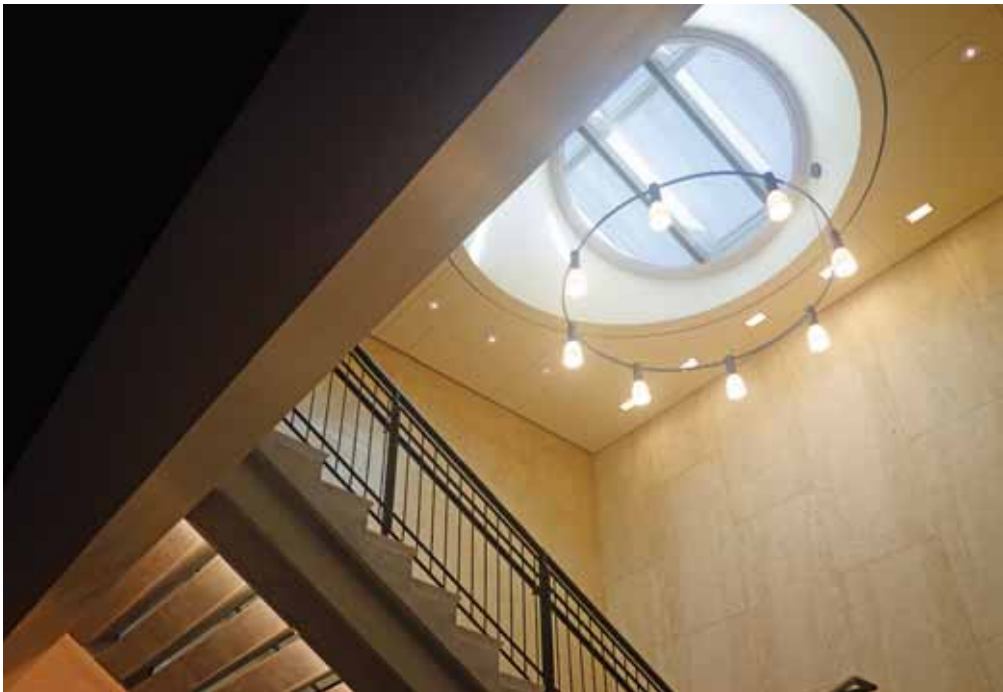

Claro is standard white unless otherwise specified. Custom colors for Claro and Metallo can be achieved by matching to a paint chip.

Claro ceiling panels are custom colored to match stone finish on walls in this unique observatory stairway.

Claro[®]

Featured in Large Panels



This impressive ceiling is the architectural focus for this trading floor. Panels are very large 4ft. x 10ft. factory curved in a Claro finish.

Large panels 4ft. x 10 ft. provide an architectural and acoustical element. The 90% light reflectance of Claro is ideal for indirect lighting.



Featured in Ceilencio custom suspension

Claro panels installed in our Ceilencio ceiling system provide a monolithic appearance and release downward providing convenient access to the plenum.

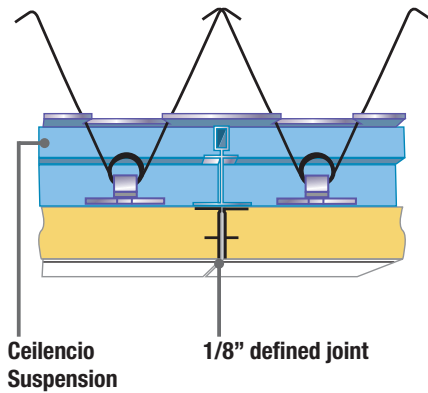

The ceilings in the baggage area of this new international airport terminal are 2ft. x 10ft. large Claro panels in the Ceilencio concealed suspension.



Custom metal reveals and perforated metal panels complete the integration of Claro panels with track lighting and custom diffusers in this Ceilencio ceiling system.

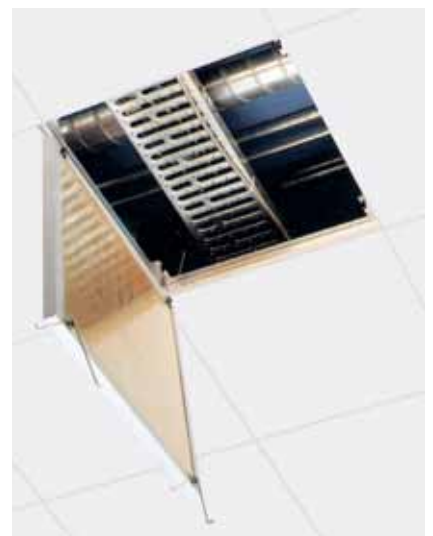

The Ceilencio system features easy installation and panels which release downward providing convenient access to the plenum.

Claro®

Featured in Custom Applications



A most unique ceiling for a corporate headquarters office. The custom wave shape elements are finished in Claro. Decoustics supplied custom precurved carrying channel.

Curved Claro finished panels with 90% light reflectance, in a fully accessible Ceilencio ceiling, became the signature of this large prestigious international headquarters building.



Featured in Designed Returns



Factory engineered custom perimeter profiles are available fully integrated into this accessible Ceilencio ceiling system.

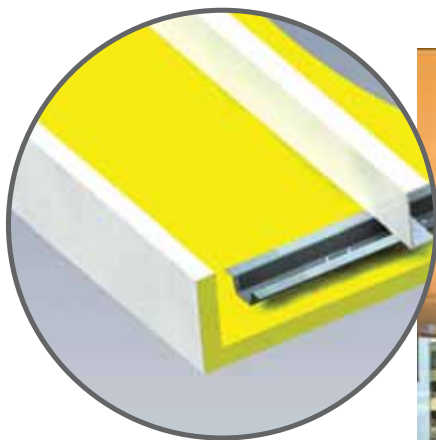

Custom shaped, Claro finished panels, direct mount with integral returns complete the design of this high profile boardroom.

DECOUSTICS®
ECOPHON®
GYPTONE®
PERFORMA™



You can Be Certain™ that Decoustics will free you to bring your one-of-a-kind ceiling design to life. Its dramatic custom forms are engineered with exceptional precision to make even your most elaborate vision a possibility. And as part of CertainTeed Ceilings, we offer the expertise to help you ensure every space achieves ideal Environmental Acoustics™ for a healthier indoor environment. Our solutions promote well being and productivity in any setting so every person can achieve their greatest potential. Through deep industry knowledge, continual innovation and sustainable efforts, we empower you to provide a sounder environment in any setting.